

PARTS SCHEMATIC

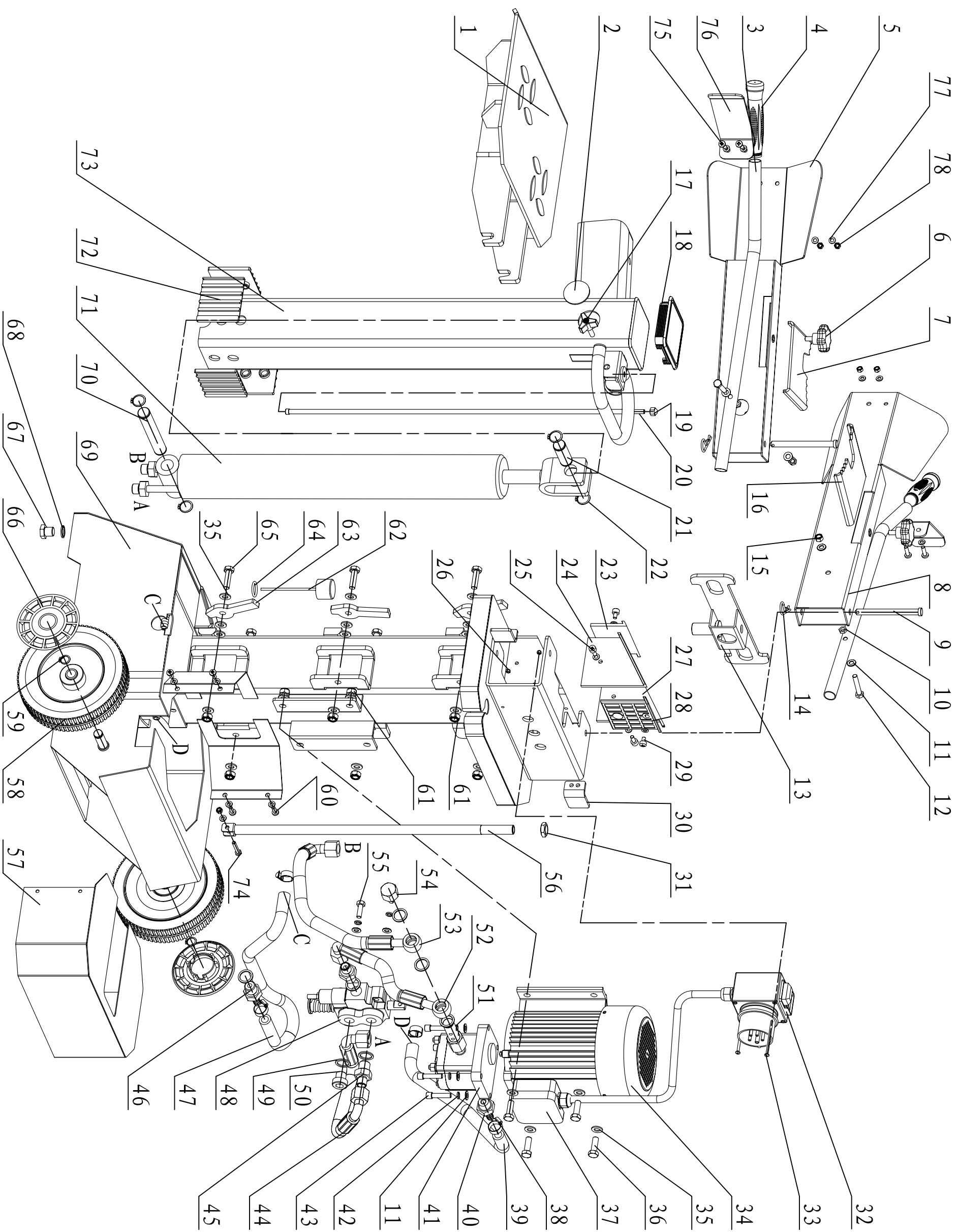

6吨立式劈木机零件清单表

序号	Description	名称	数量
1	Work Table	托木台2	1
2	Round Cover	圆堵	2
3	Operate Handle	操纵手把	2
4	Lever Handle	Φ22手把套	2
5	Right Guard Assy.	右护手把总成	1
6	Knob	星型手把	2
7	Clamping Fork2 (Right)	夹木抓2	2
8	Left Guard Assy.	左护手把总成	2
9	Control Lever Shaft	护手把销轴	2
10	Thin Nut	M8薄螺母	2
11	Washer 8	垫圈 8	10
12	Hex Bolt	外六角螺栓M8*45	2
13	Control Link Plate	调节杠杆	1
14	Fork	Φ3卡子	2
15	Locknut M8	防松螺母 M8	4
16	Clamping Fork1 (Left)	夹木抓1	1
17	Knob	四星手把	1
18	Square Cover	方盖	1
19	Nut	M8组合盖螺母	1
20	Draw Rod	拉杆	1
21	Pin	短轴d	1
22	Circlip 22	轴用挡圈 22	4
23	Plastic Insert1	上滑板1	1
24	Plastic Insert4	上滑板4	1
25	Inner Hexangular Screw M6x16	M6*16内六角螺钉	2
26	Locknut M4	防松螺母 M4	2
27	Plastic Insert 2	上滑板2	1
28	Plastic Insert 3	上滑板3	1
29	Inner Hexangular Screw M6x10	M6*10内六角螺钉	2
30	Stop Limit Plate	护手把限位板	2
31	Thin Nut M16	M16薄螺母	1
32	Switch	开关	1
33	Screw M4x6	M4*6螺钉	2
34	Motor	电机	1
35	Washer 10	垫圈 10	32
36	Bolt M10x30	M10*30螺栓	4
37	Junction Box	接线盒	1
38	Hose Clamp	双钢丝喉箍 15-26	4
39	Intake Hose	吸油管	1
40	Pump Intake Nozzle	泵吸油嘴	1
41	Gear Pump	齿轮泵	1

42	Spring Washer 8	弹垫 8	6
43	Inner Hexangular Screw M8x35	M8*35内六角螺钉	4
44	High Pressure Oil Hose 3	高压油管3	1
45	Valve Tube Nozzle	阀管油嘴	2
46	Valve Injection Nozzle	阀出油嘴	1
47	Oil Return Pipe	回油管	1
48	CA Valve	CA阀	1
49	Washer Groupware 20	组合垫 20	6
50	Valve Plug	阀堵	1
51	T-Connector, Tape	锥丝三通	1
52	High Pressure Oil Hose1	环形高压油管1	1
53	High Pressure Oil Hose2	环形高压油管2	1
54	T-Plug, Nut	三通盖螺母	1
55	Bolt M8x25	螺栓 M8x25	2
56	Draw Sleeve	拉管组焊件	
57	Pump Guard	泵护罩	1
58	Wheel	轮子	2
59	Circlip 16	轴用挡圈 16	2
60	Screw M6x16	螺钉 M6x16	4
61	Locknut M10	M10防松螺母	10
62	Cap	加油嘴盖	1
63	Lock-out Lever	锁紧手把	6
64	O-Ring 32x3.55	O型圈32*3.55	1
65	Bolt M10x35	螺栓 M10x35	6
66	Wheel Cover	轮盖	2
67	Bolt M16x25	螺栓 M16x25	1
68	Washer Groupware 16	组合垫 16	1
69	Upright Tube Weldment	立管焊接总成	1
70	Lock Shaft	下轴	1
71	C3 Cylinder	C3油缸	1
72	Sliding Plate	滑板	4
73	Wedge Bracket Weldment	刀架管总成	1
74	Bolt M6x30	螺栓 M6x30	1